

## GrowControl™ GC-4 Environmental Controller



### Installation & User Operation Manual

 **DANGER**

**Risk of Electric Shock!**

This system operates on 120V and can cause electric shock resulting in injury or death.  
**Read all warnings** and instructions before operating this equipment.



 **WARNING**

The controller enclosure, sensors and accessories are not rated for water contact.  
**DO NOT** expose to direct, spray, splashing, misting or other water contact!

 **WARNING**

Read these requirements, installation and operating instructions very carefully. Failure to follow the instructions could result in a controller malfunction. A malfunction could result in serious equipment damage, property damage, bodily injury or death.

## Installation Instructions

### Mounting the Controller:

Your controller can be mounted to any wall using the four holes in the mounting flanges. Do not over-tighten the mounting screws as this may cause breakage of the mounting flanges.

The controller must be mounted **upright** on a vertical wall to ensure maximum controller life.

Keep in mind the maximum allowable temperature and humidity when selecting a location to mount the controller. Make sure the controller, sensors, and other controller accessories are not in a splash, drip or other water contact location.

 **NOTICE!**

DO NOT over-tighten the mounting screws!

## Circuit Breaker

This controller is equipped with a 15 amp thermal circuit breaker. Exceeding the rated current will cause the circuit breaker to shutdown the controller. Wait 60 seconds and then press the reset button. You should hear/feel a click and the controller should restart.

 **FOR YOUR SAFETY**

This controller is equipped with a grounded power lead and must be wired into a **properly grounded** outlet. **DO NOT** remove the ground terminal from the plug. **DO NOT** circumvent the ground terminal.

# Setup Overview

1. Attach equipment according to the labels on the side of the controller.  
**DO NOT place any plug other than the designated sensor plug into any sensor port!**
2. Plug the controller power cord into a suitable minimum 15Amp 120V circuit.  
*(We recommend a dedicated circuit with GFCI protection & a surge suppressor!)*
3. Set timers and properties to desired values.
4. Place the controller into "Run" mode to make equipment operational.

## Typical Hook-Up Diagram:

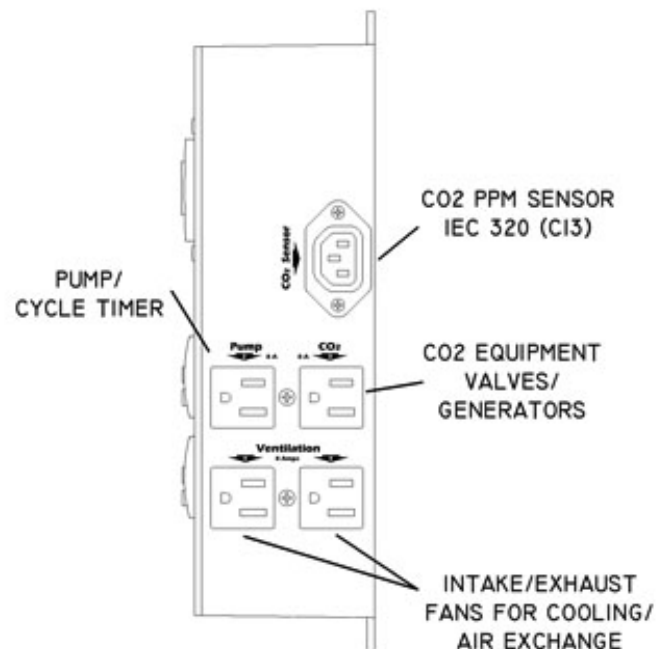
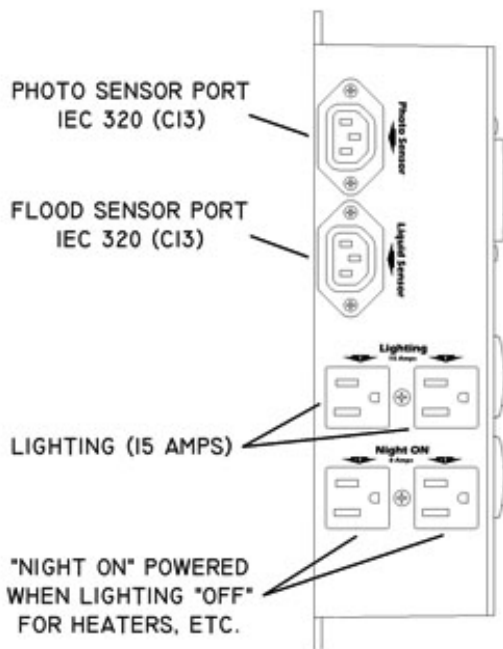
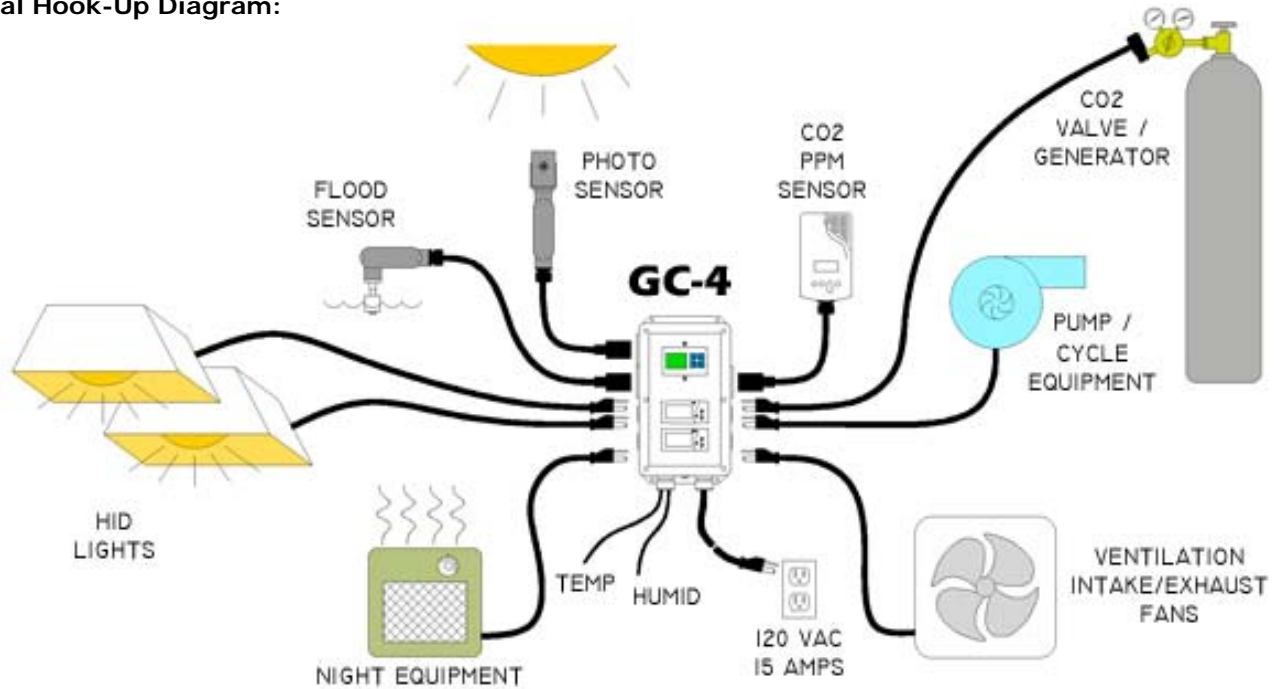

# Operating Instructions

## Setting Up Your Controller:

When you plug in your controller, it should be in the STOP condition; this prevents any attached devices from starting as soon as the unit is plugged in.

## The Screen and Key Pad:

The figure below shows the main, or **home screen**, of the controller; here a variety of current controller status data is displayed.

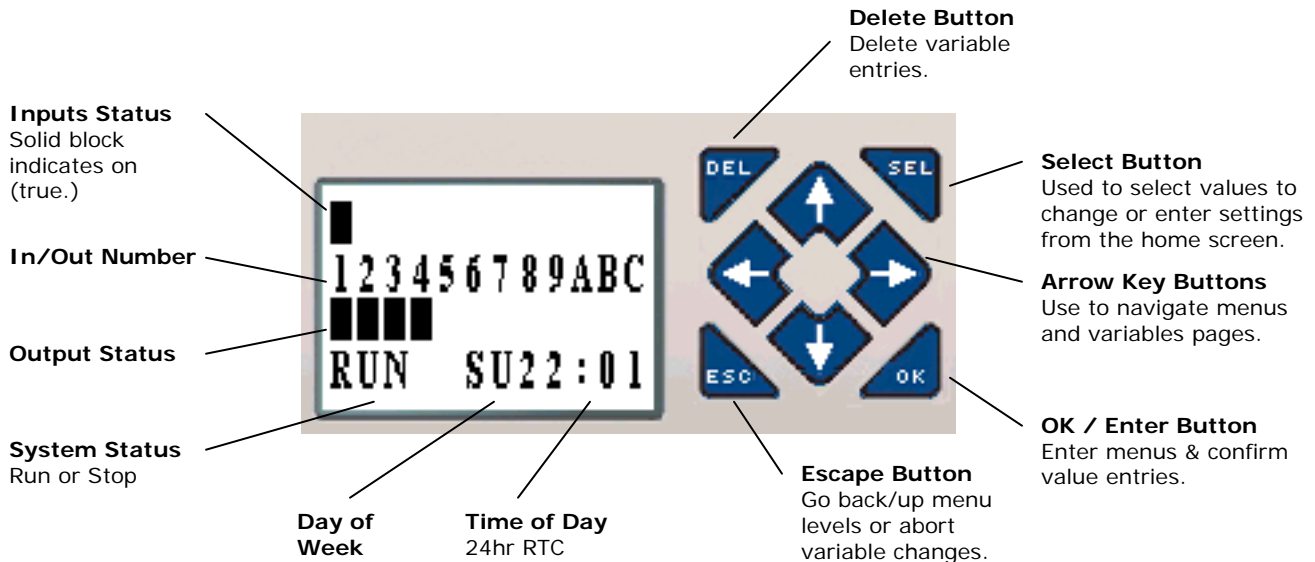

## Setting the Time and Date:

From the main screen, press the **ESC** key to enter the system menu.

1. Using the arrow keys, scroll down to "**RTC SET**" and press **OK**.
2. Press **SEL** and use the arrow keys to adjust the date and time; use the left and right arrow keys to move between the date and time values, and the up and down arrow keys to adjust the values. (Note: the real time clock (RTC) operates on 24 hour time instead of AM/PM.)
3. When you are finished, press **OK** and then **ESC** to return to the system menu.
4. Press **ESC** again to return to home screen.

At the main screen the time and day should now be accurate. Press the **UP** arrow key to check the date; press the **DOWN** arrow key to return to the main screen. (Continuing through the other screens displays internal program status' which are generally used for diagnostic purposes.)

## Running Your Controller:

When the controller is in **STOP** mode, the program is not running and all of the outputs are disabled. To run the controller, it must be placed into **RUN** mode.

1. If the system status is "**STOP**," from the main screen, press the **ESC** key to enter the system menu.
2. Using the arrow keys, scroll down to "**RUN**" and press the **OK** button.
3. The controller will ask if you are sure you want to run the program; select **YES** and press **OK**.
4. The controller should start.
5. Press **ESC** to return to the main menu. Verify the system status is now "**RUN**."

ALWAYS place your controller into **STOP** mode before powering it down. This prevents the possibility of accidental equipment startup.

# Changing the Timers

This controller has an advanced set of digital timers, clocks and counters in conjunction with a software program that offers complex control of your equipment. The **variables** are customer adjustable values, usually times, cycle timers and counters, that can be set very easily on the controller screen.

## Accessing the Variables Pages and Changing the Values:

1. From the main [home] screen press **SEL**. A screen with manufacturer & model information should appear.
2. Press the **DOWN** arrow to scroll through the many controller options.
3. To change a given variable, press **SEL** and use the arrow keys to navigate to the property and digit you wish to change.
4. Press **SEL** again and use the **UP** and **DOWN** arrow keys to change the values.
5. When you are finished, press **OK** (or press **ESC** to cancel your changes.)
6. Press **ESC** to continue moving through the variables pages.

The final page contains the software version number, date and copyright notice. Press **ESC** to return to the home screen. Please see "troubleshooting" if you cannot get back to the home screen.

## Repeat Cycle Timers:

Setting the Pump, Ventilation, or other cycle timers is the same basic procedure.

Cycle timers have an "on" time and an "off" time which you can specify in any amount between 1-9999 minutes. Setting an "on" time of "0002" and an "off" time of "0005" will make the device run for two minutes and rest off for five minutes before powering on again for another two minutes and so on.

Most cycle timers will have settings for the day and the night. Day cycles will operate any time the lighting is scheduled to be on (even if photo-sensor [optional] shuts the lighting off during the day.) Night cycles will operate any time the lighting is scheduled to be off.

Cycle timers can be set to operate or not operate based on the values you enter. This can be useful for disabling a device, such as pumps during the night, by setting the night cycle timer to cancel.

## Timer Settings & Options:

Timers can be configured to operate constantly, operate once or not operate at all based on the time values you enter.

### To cancel a timer:

1. *In the Night:* Set the **Night On** time value to **0** and the **Night Off** time value to **9999**.
2. *In the Day:* Set the **Day On** time value to **0** and the **Day Off** time value to **9999**.

### To operate once:

1. Set the **On** time to any value **equal or greater than 1**.
2. Set the **Off** time to **9999** minutes.

### To operate a timer continuously:

1. Set the **On** time to **9999**
2. Set the **Off** time to **0**.



## **WARNING**

***DO NOT*** set both time values to 0; this will cause damage to the controller!

# Lighting Schedule

Access the "Light Timing" screen by pressing **SEL** from the main screen and navigating **DOWN**.

The first line contains the range of days of the week the lighting is to operate. Your controller is set to run Sunday (SU) to Saturday (SA) this indicates all 7 days of the week.

The second and third lines indicate the daily on and off times; times are set in 24 hour time.

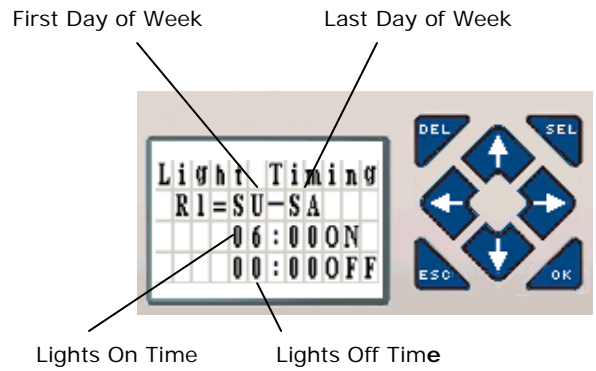

## Photo Sensor:

A photo sensor is optional and plugs into the "Photo Sensor" port on the side of the controller. When the sun is detected by the sensor, the controller will shut off the lighting output (but will remain in "day" mode until the 24hr lighting timer trips to "night.") This is useful for greenhouse application where lighting is used for photo-period supplementation.



## Example:

The lighting timer is scheduled from 06:00 to 22:00. If the sun is not present at 06:00, the lighting will turn on and the controller will go into "day" mode. When the sun comes up the lighting will be turned off. If the sun sets at 21:00, the lighting will operate an additional hour until 22:00 when the 24hr timer shuts off and the controller goes into "night" mode.

## High Power Relays:

High power relays are required if you are going to exceed 1000 Watts of lighting through your controller. High power relays have a set of receptacles for equipment to plug into, a power cable to power the receptacles from a separate circuit, and a control (or "trigger") cable to turn the receptacles on.



# Pump Operation

The pump circuit is operated by a repeat cycle timer with separate time settings for day and night. This allows the pumps to be operated intermittently or constantly 24hours a day, only during the day, or once per day. See the "Timers & Settings" section above.

## Example:

Many hydroponics systems require the pumps to be circulated frequently in the day and less frequently at night. In this case the "Pump Day" cycle timer would have long on times and short off times, while the "Pump Night" cycle timer would have short on times and long off times.

In other situations a pump may need to operate all day long while remaining off all night, in this case, set the "Pump Day" timer to constant on and the "Pump Night" timer to cancel.

See the "Timers & Settings" section above.

## Liquid Sensor:

A liquid level sensor is optional and plugs into the "Liquid Sensor" port on the side of the controller. When activated, the controller shuts down the pump, lighting and CO2 equipment to prevent flooding. Ventilation equipment remains active to ensure the proper atmospheric conditions at all times.



# Ventilation Temperature/Humidity Control

Temperature/Humidity controls over-ride ventilation cycle timers and CO2 functions in the event ambient conditions rise (or fall) below the set-points. Temperature and humidity controls can operate in conjunction with ventilation cycle timers or without. When timers are set to the off configuration, ventilation will be operated only by the temperature and humidity controllers.

## Example:

A typical configuration involves setting the ventilation day cycle timers to off, while setting a minimum cycling time for the night. This allows the thermostat & humidistat to control the ventilation during the day without any timer-based operation, and at night the ventilation night cycle timer will operate the ventilation on a regular interval to ensure proper air exchange. Temperature and humidity control will still over-ride cycle timers in the event conditions become too hot or humid.

## Changing the Set Point:

1. Press the **SET** button; SP displays on the screen
2. Press **SET** again and the set point displays on the screen
3. Use the **UP** & **DOWN** arrows to set the set point
4. Press **SET** to confirm the new set point
5. Press **SET & DOWN** simultaneously or wait one (1) minute to exit programming mode

## Changing from Cooling to Heating (or Dehumidifying to Humidifying)

1. Hold **SET** for **8 seconds**
2. The access code 0 is displayed. (This value may be changed, but we recommend leaving as 0\*.)
3. Press **SET** to enter the access code
4. SP is displayed on the screen. Use the arrow keys to navigate to "**d0**"
5. Press **SET** and use the arrow keys to change the value.
  - a. d0=Co – Cooling
  - b. d0=Ht – Heating
  - c. d0=Hu – Humidifying
  - d. d0=Dh – Dehumidifying
6. Press **SET** to enter the value and exit
7. Press **SET & DOWN** simultaneously or wait one (1) minute to exit programming mode

The temperature differential is the amount of degrees above (or below) the set point the controller will allow before activating.

## Example:

A set point of 70°F and a differential setting of 5° will cause the controller to turn on ventilation at 75°F until it returns to 70°F.

## Setting the Differential / Hysteresis

1. Hold **SET** for **8 seconds**
2. The access code 0 is displayed. (This value may be changed, but we recommend leaving as 0\*.)
3. Press **SET** to enter the access code
4. SP is displayed on the screen. Use the arrow keys to navigate to "**r0**"
5. Press **SET** and use the arrow keys to change the value.
6. Press **SET** to enter the value and exit
7. Press **SET & DOWN** simultaneously or wait one (1) minute to exit programming mode

## Sensor Probe Offset (Calibration)

8. Hold **SET** for **8 seconds**
9. The access code 0 is displayed. (This value may be changed, but we recommend leaving as 0\*.)
10. Press **SET** to enter the access code
11. SP is displayed on the screen. Use the arrow keys to navigate to "**P1**"
12. Press **SET** and use the arrow keys to change the value.
  - a. Temperature offset -10 to +10 degrees
  - b. Humidity offset 0 to 10% RH
13. Press **SET** to enter the value and exit
14. Press **SET & DOWN** simultaneously or wait one (1) minute to exit programming mode

\* The access code can be reset by turning the controller off and holding **SET** while turning the controller on.

# CO<sub>2</sub> Control

CO<sub>2</sub> can be operated by a repeat cycle timer or by PPM sensor control. To operate by PPM sensor, plug the sensor cord into the port labeled "CO<sub>2</sub> Sensor" and set the timers per the PPM Monitor section below.

CO<sub>2</sub> is dispensed only during the lighting cycle. When using the cycle timers, CO<sub>2</sub> is dispensed in a cycle of seconds on, and minutes off. A maximum CO<sub>2</sub> timer is set to limit the amount of CO<sub>2</sub> dispersion time per day; this helps conserve the use of CO<sub>2</sub> and prevent accidental waste in the event of an unusual condition.

If a thermostat or humidistat is present, and conditions are above either set point, CO<sub>2</sub> will be cancelled until the environment has been cooled or dehumidified by the ventilation equipment.

**CO<sub>2</sub> On Time:** The time in seconds for the solenoid valve (or CO<sub>2</sub> generator) to remain on. This timer CAN be interrupted by temperature and humidity controls to activate the ventilation output.

**CO<sub>2</sub> Off Time:** The time in minutes between CO<sub>2</sub> emission cycles. This timer CAN be interrupted by temperature and humidity controls to activate the ventilation output.

**CO<sub>2</sub> Absorb Time:** The time in minutes to disable the ventilation output each time the CO<sub>2</sub> output is enabled. This timer can NOT be interrupted by temperature and humidity controls. This timer, if activated, will take the place of the "CO<sub>2</sub> Off Time" timer. *Set to "0000" to disable this timer.*

**Force Vent after CO<sub>2</sub> Off cycle:** The amount of time that ventilation fans will operate after each "CO<sub>2</sub> Off Time" cycle. After the ventilation cycle completes, the CO<sub>2</sub> cycle restarts. (This timer is disabled when using the "CO<sub>2</sub> Absorb Time" timer.) *Set to "0000" for no ventilation cycle between CO<sub>2</sub> cycles.*

**Max CO<sub>2</sub> Time per Day:** The maximum number of CO<sub>2</sub> time you want to allow per day. CO<sub>2</sub> will be canceled for the remainder of the lighting cycle after this limit is reached. *Enter 9999 to place no limit on CO<sub>2</sub> time per day.*

## PPM Monitor:

To use the PPM monitor to control CO<sub>2</sub> emissions, setup your controller following the steps below.

1. Place the controller into **"STOP"** mode. This will turn off all equipment.
2. Set the "CO<sub>2</sub> ON Time" to **0000** and the "CO<sub>2</sub> OFF Time" to **0000**.
3. Set "Max CO<sub>2</sub> On Time per Day" to **9999** for no daily limit.
4. Set "Force Vent After CO<sub>2</sub>" timer to **0000**.
5. Plug PPM monitor into "CO<sub>2</sub> Sensor" socket on the side of the controller.
6. Set the desired PPM level on the PPM monitor (*see below.*)
7. Place the controller into **"RUN"** mode.

## Setting PPM Level:

1. Allow monitor to exit warm-up mode
2. Hold **CLEAR + MODE** for 5 seconds until menu appears
3. Press **MODE** until you reach the "RELAY" setting\*\*
4. Use the **UP/DOWN** arrow keys to adjust the PPM setting; default is 1000ppm
5. Press **ENTER** to confirm your setting
6. Press **MODE** and adjust the "HYSTERS" hysteresis setting to the desired level;
7. default is 50ppm
8. Press **ENTER** to confirm your setting
9. Press **MODE** again to exit the menu



The hysteresis is subtracted from the set point and acts as the point at which the controller begins to operate CO<sub>2</sub> until it returns to the set point.

**\*\*If you do not see RELAY or HYSTERS options, make sure the controller is set to "NONSTD" instead of one of the numbered standard settings.**

Note: Because CO<sub>2</sub> is denser than air, it has the tendency to fall to the ground unless it is disturbed by fans. Because of this, emitters must be placed above the plants and fans must be used to circulate the air volume. This can help prevent excessively high concentrations of CO<sub>2</sub> at the plant level.

# Specifications

Input Voltage	120 VAC 50/60Hz
Maximum Current Capacity	15 Amps @ 120VAC
Overload Protection	15 Amp thermal circuit breaker w/reset button
Operating Temperature	32-131°F (0-55°C)
Maximum Humidity	90% RH (Non-condensing)
Temperature Control Range	0-150°F (0-65°C) w/2°F differential (user set)
Humidity Control Range	0-100% RH w/5% differential (user set)
OUTPUT 1: Lighting Circuit Capacity	15 Amps @ 120VAC
Lighting Timer	Digital 24hour real time clock
"Night ON" Circuit Capacity	15 Amps @ 120VAC
"Night ON"	"ON" when Lighting Circuit is OFF
OUTPUT 2: Pump Circuit Capacity	8 Amps @ 120 VAC
Pump ON timer Day	0-9999 minutes
Pump OFF timer Day	0-9999 minutes
Pump ON timer Night	0-9999 minutes
Pump OFF timer Night	0-9999 minutes
OUTPUT 3: Ventilation Circuit Capacity	8 Amps @ 120 VAC
Ventilation ON timer Day	0-9999 minutes
Ventilation OFF timer Day	0-9999 minutes
Ventilation ON timer Night	0-9999 minutes
Ventilation OFF timer Night	0-9999 minutes
OUTPUT 4: CO2 Circuit Capacity	8 Amps @ 120 VAC
CO2 On-Delay Timer	0-9999 minutes
CO2 On Timer	0-9999 seconds
CO2 Off Timer	0-9999 minutes
Fan delay off time	0-9999 minutes
CO2 max cycles per day	0-99999 cycles
PPM Sensor Range	0-10,000 PPM
PPM Sensor Set Point	0-10,000 PPM by 25 PPM
PPM Sensor Hysteresis	0-10,000 PPM by 5 PPM
PPM Sensor Accuracy	± 100 PPM or 7%
PPM Sensor Response Time	Less than 1 minute
PPM Sensor Warm-Up Time	Less than 2 minutes
PPM Sensor Operating Temperature	60-90°F (15-32°C)
PPM Sensor Operating Humidity	0-95% RH (Non-condensing)
PPM Sensor Altitude Above Sea Level	0-10,000 Ft
Relay Operation	100,000 mechanical / 10,000,000 electrical

# Troubleshooting

## PROBLEM:

No power, the controller is not lighting up.

The controller is on, but the equipment is not operating.

I can't get to the home screen. When pressing **ESC** I get some unknown screen instead.

When changing a variable time [I accidentally pressed **SEL** and] the numbers changed to something else.

## SOLUTION:

-Check to make sure the unit is plugged in.  
-Make sure the circuit has power; use another working device such as a lamp to make sure.  
-Ensure the circuit breaker on the controller is not tripped. Try to reset it by pressing the button.

Ensure the controller is in "RUN" mode and the home screen does not say "STOP." If it does, you must place the controller into RUN mode (see p.2.)

Press **ESC** until you reach the unknown screen (you will toggle between the system menu and the unknown screen.) Now press the **UP** (or **DOWN**) arrow until the main screen appears. (This shifts through the status of the internal program which is used for diagnostics.)

Press **ESC** and the original value will be returned; then press **SEL** again to edit the value.

# Maintenance

This controller does **not** require maintenance.

**DO NOT** open the controller enclosure. There are no user serviceable parts inside the controller.

The controller may require cleaning with a damp, soft cloth. Do not spray the controller with cleaners or use cleaners which may be harmful to plastics. Do not use abrasive detergents, petrol, alcohol or solvents.

# Warranty

Agrowtek Inc. warrants that all manufactured products are, to the best of its knowledge, free of defective material and workmanship and warrants the components for the following period from the date of purchase:

GrowControl™ Controller System:       **2 Years**  
Sensors & Accessories:                   1 Year

This warranty is extended only to the original purchaser of the equipment from the date of purchase detailed on the purchase invoice.

This warranty does not cover damages from abuse, accidental breakage, or units that have been modified, altered, or installed in a manner other than that which is specified in the installation instructions.

Agrowtek Inc. must be contacted prior to return shipment for a return authorization. No returns will be accepted without a return authorization. The original purchase invoice must accompany any warranty claims.

This warranty is applicable only to products that have been properly stored, installed, and maintained per the installation and operation manual and used for their intended purpose. This limited warranty does not cover products installed in or operated under unusual conditions or environments including, but not limited to, high humidity or high temperature conditions.

The products which have been claimed and comply with the aforementioned restrictions shall be replaced or repaired at the sole discretion of the Agrowtek Inc. at no charge.

This warranty is provided in lieu of all other warranty provisions, express or implied. It is including but not limited to any implied warranty of fitness or merchantability for a particular purpose and is limited to the Warranty Period.

In no event or circumstance shall Agrowtek Inc. be liable to any third party or the claimant for damages in excess of the price paid for the product, or for any loss of use, inconvenience, commercial loss, loss of time, lost profits or savings or any other incidental, consequential or special damages arising out of the use of, or inability to use, the product. This disclaimer is made to the fullest extent allowed by law or regulation and is specifically made to specify that the liability of Agrowtek Inc. under this limited warranty, or any claimed extension thereof, shall be to replace or repair the Product or refund the price paid for the Product.

*This warranty provides the purchaser with specific rights but the claimant may have other rights which vary from jurisdiction to jurisdiction.*