

pH, Temperature (+ORP/DO) Transmitter & Data Logger



Shown with optional sensor probes



Contents

Dimensions	2	Units	12
Installation Instructions	2	Logging Interval	13
pH & ORP Probe Preparation	3	COMM Mode	14
Mounting the Transmitter	4	Device Address	14
DIN Rail Mounting Kit	4	Manufacturing Info	14
Connecting Sensor Probes	4	Display Back Light Timer	15
Connection to ADi Pump	5	Connection to 4-20mA Outputs	15
Cross-Over Cable	5	Connection to USB AgrowLINK	15
LCD Menu Operation Instructions	6	Connection to MODBUS RTU	16
High / Low History	6	HX8 8-Port Hubs	16
Graphing	6	MODBUS Serial Speed & Format	16
Main Menu	7	Supported Commands	17
Alarms Menu	7	Register Types	17
Alarms Configuration	7	Sensor Value Registers	17
Alarm Buzzer	8	Calibration Registers	17
Calibration Menu	8	MODBUS Register Map	18
Temperature Calibration	8	Maintenance	19
pH Calibration	9	Probe Cleaning	19
O.R.P. Calibration	10	pH Probe Reconditioning	19
Clear Calibration	10	Technical Information	20
Advanced Calibration	11	Specifications	20
Analog Output Calibration	11	Storage & Disposal	20
Setup Menu	12	Warranty	20
Time / Date	12		

Dimensions

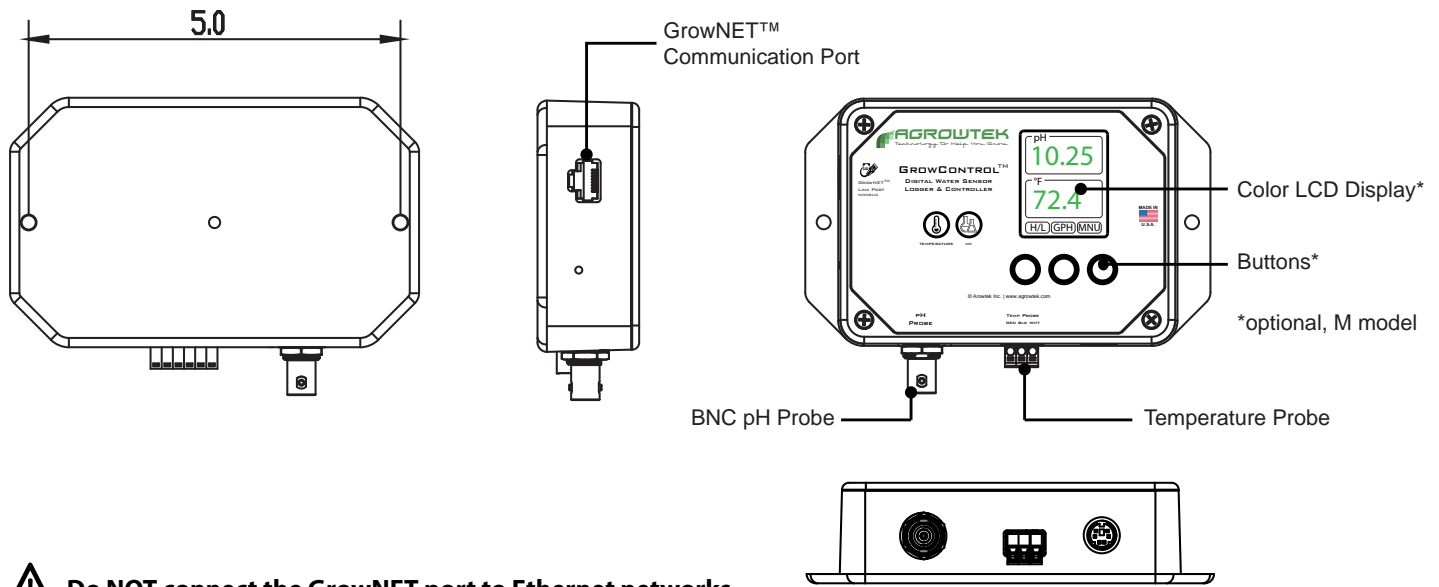

⚠ Do NOT connect the GrowNET port to Ethernet networks.

Installation Instructions

Install with the connections facing down to reduce the risk of water permeating the enclosure.

Avoid locations with dripping water or heavy splash risk; the transmitter is best kept dry for longest life and highest accuracy.

A probe manifold with recirculating pump (3-30gpm) is recommended for best sensor accuracy.

IMPORTANT NOTE: For flow rates above 5 gpm, ensure probe tips are raised out of the flow path to prevent turbulence altering the sensor readings.

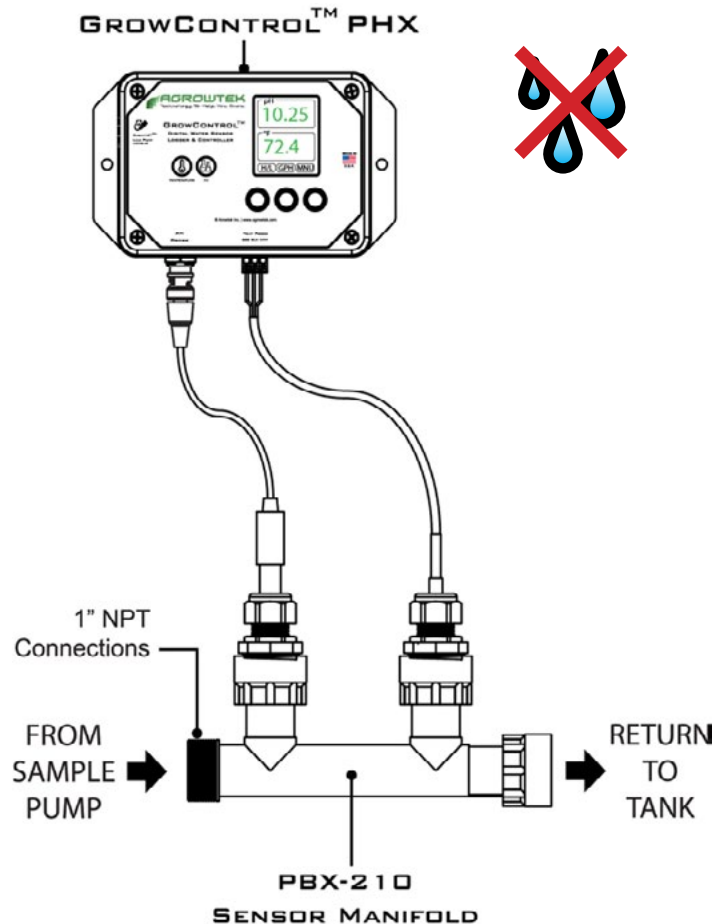
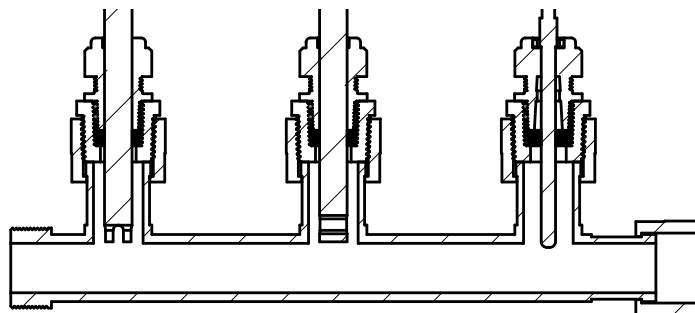

pH & ORP Probe Preparation

Probe Shipping & Storage

pH & ORP probes are shipped in a plastic bottle containing a solution of pH 4 buffer and potassium chloride. The electrode should remain in the bottle until it is used.

If the electrode is used infrequently, the bottle and its solution should be saved and the electrode stored in it. If the solution in the soaker bottle is missing, fill the bottle with pH 4 buffer.

Take out electrode by loosening plastic top on bottle counter-clockwise and pulling electrode out. Slide cap and O-ring off electrode and save.

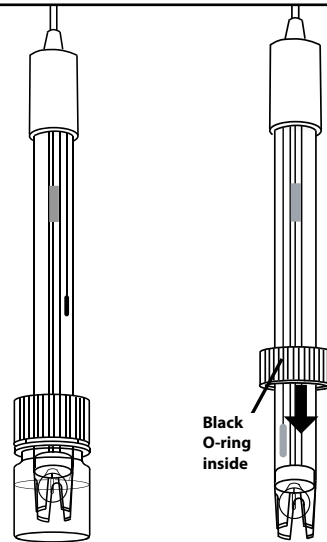

Air Bubble

During shipment the air bubble in the electrode's stem may move into the bulb area.

If bubbles are seen in the bulb area, hold the electrode by its top cap and shake while pointed downward.

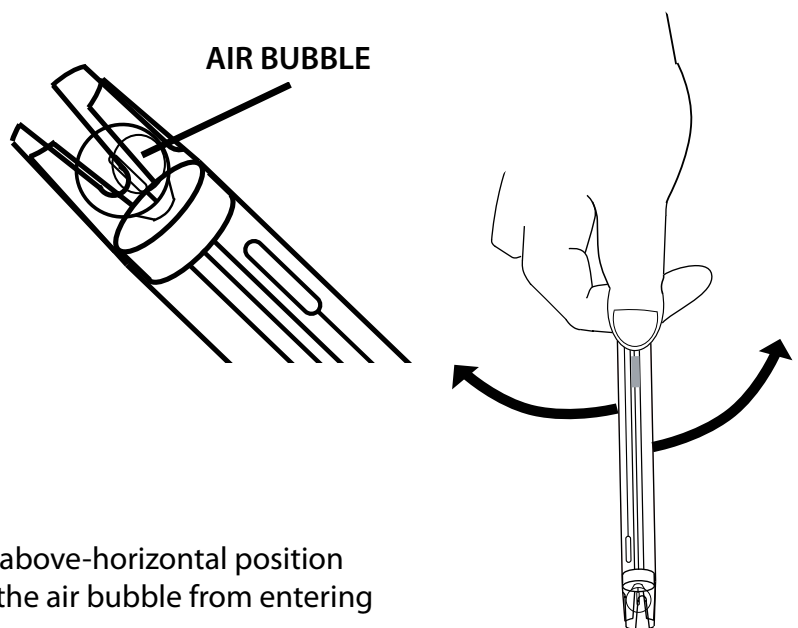

⚠ Installation/Operation Angle

pH & ORP sensor probes must be installed in an above-horizontal position with the probe tip facing downward to prevent the air bubble from entering the the bulb area.

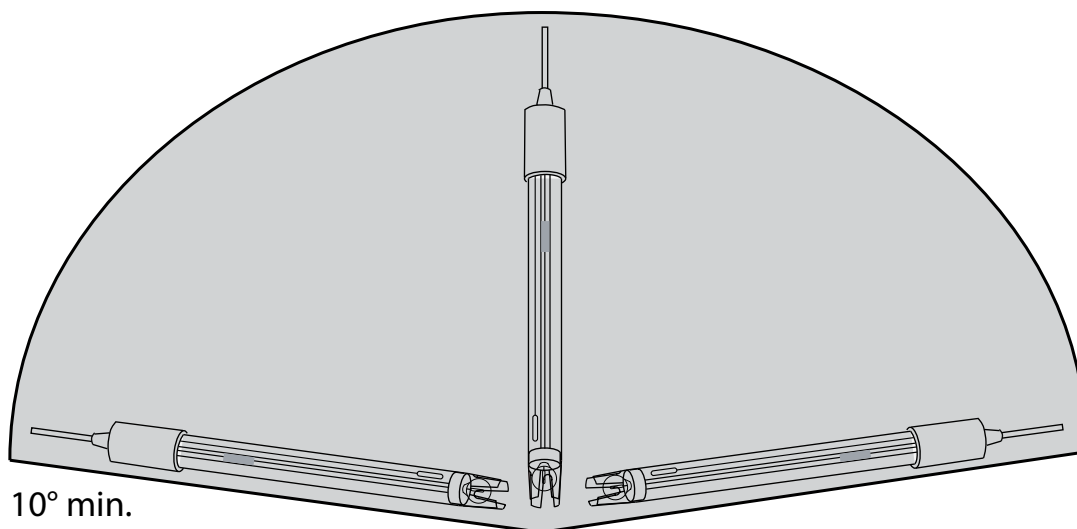

Mounting the Transmitter

Wall mounting tabs are provided for installing against a vertical wall surface.

1. Measure out the hole locations per the dimensions, or mark the holes using the transmitter as a template.
2. Drill holes and install anchors (if required, not included.) Keep the transmitter away from dust during work.
3. Install the transmitter to the wall surface using appropriate screws.

DIN Rail Mounting Kit

A DIN rail mounting kit installs onto the mounting flanges with the provided hardware for mounting the device on a standard DIN rail.

1. Screw the DIN rail brackets onto the flanges using the provided screws.
2. Snap the transmitter into place on a DIN rail.
3. Use the latches on the DIN brackets to release the transmitter from the DIN rail.



Connecting Sensor Probes

pH and ORP or DO sensors are equipped with "BNC" style connectors which push on and then turn 1/4 rotation CW to lock them in place. Temperature and EC probes have a screw terminal block; make the connections according to the label on the transmitter. The terminal block may be removed for easier wire installation or for service.

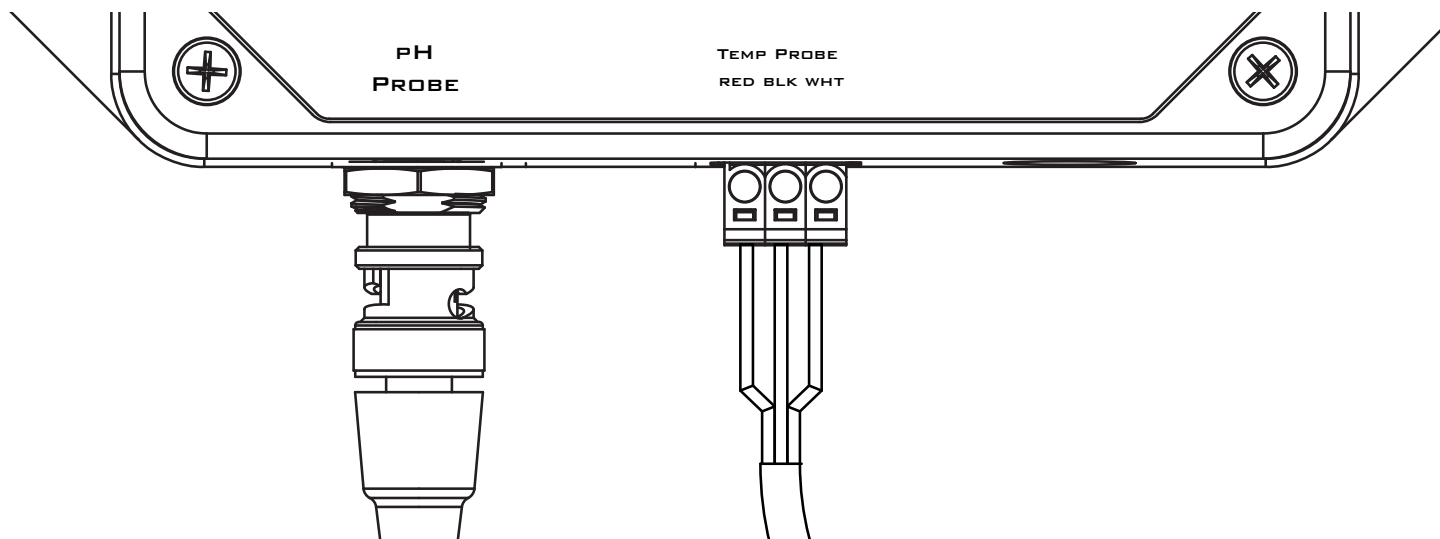

pH probes must remain wet to avoid damage. Do not allow probe tips to dry.

Connection to ADi Pump

A direct-link connection between a PHX sensor and ADi pump requires Agrowtek's cross-over adapter.

⚠ IMPORTANT! ONLY use cross-over adapters provided by Agrowtek. Do not use other cross-over adapters or cross-over cables unless they are constructed exactly as diagramed on the cross-over diagram. Incorrect cross-over adapters or cables can cause damage to the equipment.

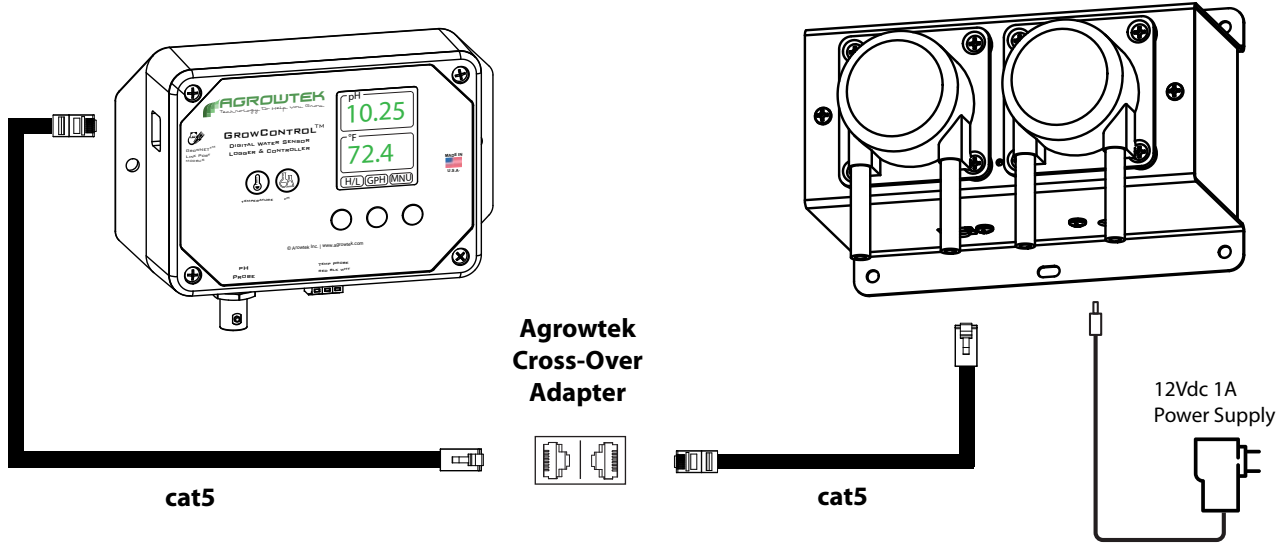

Cross-Over Cable

A custom cross-over cable can be constructed as an *alternative* to using the cross-over adapter and two standard, straight Ethernet cables as shown in the diagram above.

The cross-over wiring **MUST** match the diagram. Pins 7 & 8 carry 24Vdc power and must be straight through or damage may result to the equipment.

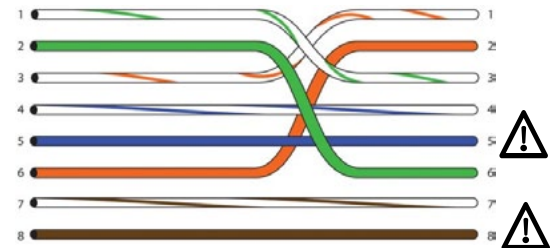

LCD Menu Operation Instructions

SXHM models with the optional 3-button/LCD display interface may be used for stand-alone monitoring applications or as part of a control solution.

Connect to Agrowtek's GrowControl facility control systems, or directly to Agrowtek's AgrowDose pumps for automatic nutrient and pH control.

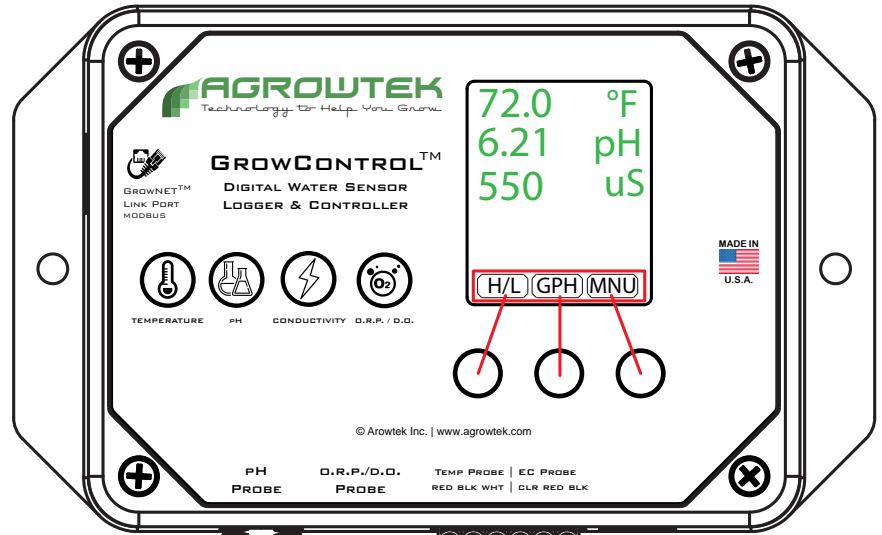

The main screen displays the real-time sensor readings from the attached sensors. Each button is labeled at the bottom of the display to describe its function on the current screen or menu.

High / Low History

H/L

Simple minimum and maximum recorded values are stored until the user resets the values to the current readings. To view the minimum and maximum values since the last reset, press the button labeled **H/L**.

To clear the min/max history, press the **RST** button to reset. The min and max values will all be set to the current readings and will update with higher or lower readings as they occur.

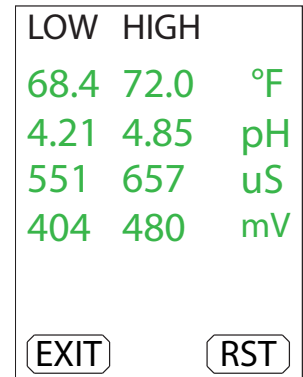

Graphing

GPH

The display can graph the most recent 120 data points from the sensor's internal data point memory. With the default logging interval of 60 seconds, the graph displays the last two hours of data.

The sensor value is plotted in green. Temperature, if overlaid on the plot, is red. Alarm levels as set by the user are plotted in yellow. Pressing the **RFH** button refreshes the data and replots the graph.

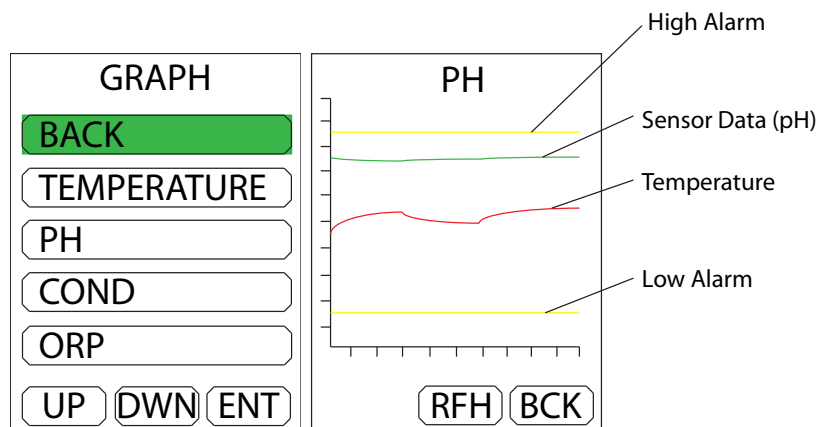

Main Menu

MNU

The main menu is how the alarms are set, sensors are calibrated and general settings such as time, date and units are configured.

If a dosing pump is directly connected to the SXHM GrowNET port, the pump settings are also accessed by the main menu.

Use the UP or DWN buttons to navigate the menu.

Use the ENT button to enter a selection.

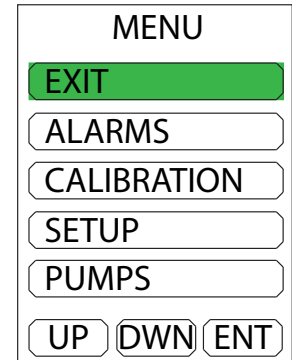

Alarms Menu

MNU ► ALARMS

High and low alarm set points may be configured for each sensor value to activate an internal buzzer or send alerts with the optional wifi module.

The out-of-range value will be displayed in red to indicate the cause for the alarm.

Additionally, alarm limits are plotted on the graphs to indicate values are within the desired range.

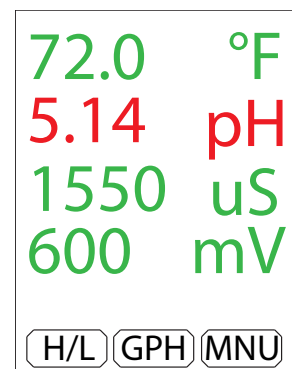

Alarms Configuration

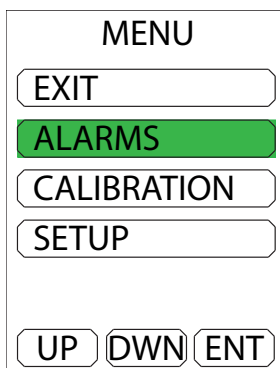

1. Select **ALARMS** from the main menu.

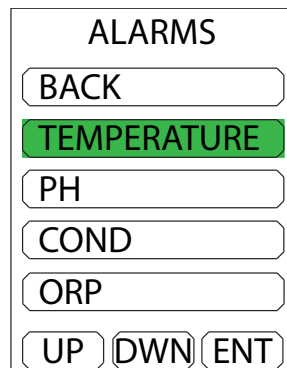

2. Select a sensor to configure set points.

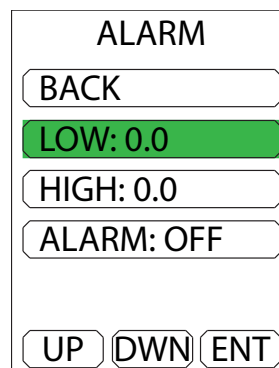

3. Select the setting to adjust.

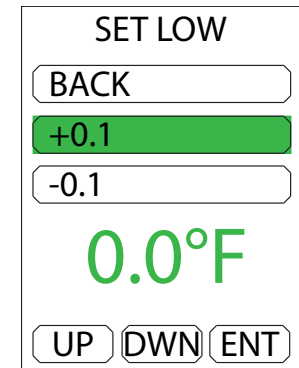

4. Adjust to the desired value. Hold UP or DWN to jog the value.

Alarm Buzzer

ALARM

BACK

LOW: 0.0

HIGH: 0.0

ALARM: OFF

UP DWN ENT

1. Select **ALARM: OFF**

SET ALARM

BACK

SET ON

SET OFF

OFF

UP DWN ENT

2. Select **SET ON** then press **BACK** to exit.

To disable the alarm buzzer, set the alarm to OFF.

Calibration Menu

MNU ► CALIBRATION

Calibration can be performed for each sensor with the LCD interface using either standard calibration wizards, or advanced manual calibration methods for non-standard calibration solutions.

The date of the last calibration for each sensor is stored in memory and displayed at the start of each calibration wizard.

MENU

EXIT

ALARMS

CALIBRATION

SETUP

UP DWN ENT

CALIBRATION

BACK

TEMPERATURE

PH

COND

CLEAR ALL

UP DWN ENT

Temperature Calibration

MNU ► CALIBRATION ► TEMPERATURE

CALIBRATION

BACK

CALIBRATE

ADVANCED

UP DWN ENT

1. Select **CALIBRATE** from the temperature calibration menu.

TEMPERATURE
LAST CALIBRATION
10/19/2017

PRESS NEXT TO
ADJUST
TEMPERATURE
READING.

EXIT NEXT

2. Press **NEXT** to continue.

OFFSET

BACK

+0.1

-0.1

72.2°F

UP DWN ENT

3. Adjust to the desired value. Hold **ENT** to jog the value by 10x.

CONFIRM?

OLD
68.1 °F

NEW
72.2 °F

YES NO

4. Confirm the new reading or press **NO** to cancel.

pH Calibration

MNU ► CALIBRATION ► PH

pH calibration is a two-point process requiring both pH 7 and pH 4.01 calibration solutions. The temperature probe must be inserted into the calibration solution at the same time as the pH probe.

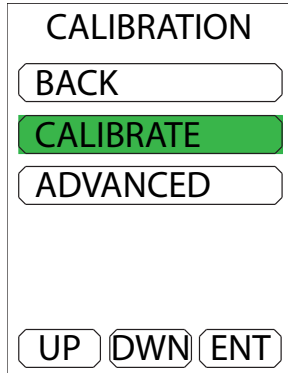

1. Select **CALIBRATE** from the pH calibration menu.

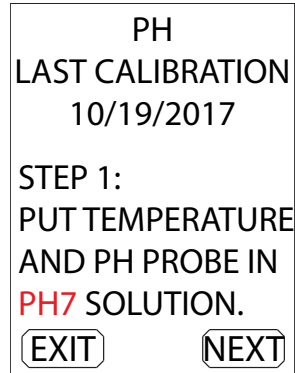

2. Follow the instructions then press **NEXT** to continue.

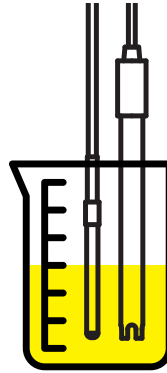

pH 7 Calibration Solution

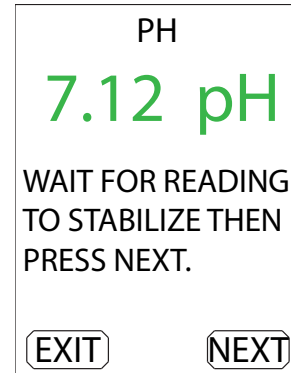

3. When the reading is stable, press **NEXT** to calibrate pH 7.

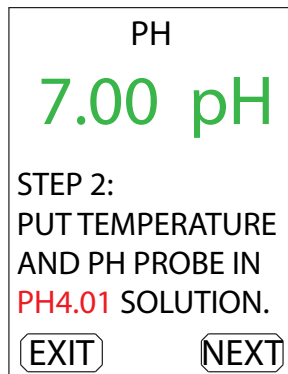

4. Clean the probes with DI/RO and change calibration solution.

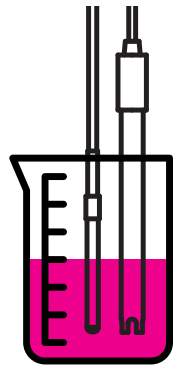

pH 4.01 Calibration Solution

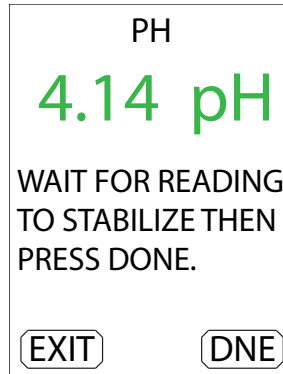

5. When the reading is stable, press **DONE** to calibrate pH 4.01 and finish calibration.

O.R.P. Calibration

MNU ► CALIBRATION ► NEXT ► ORP

ORP (optional) calibration is a single point process requiring 470 mV calibration solution.

CALIBRATION

BACK

CALIBRATE

ADVANCED

UP DWN ENT

1. Select **CALIBRATE** from the conductivity calibration menu.

ORP

LAST CALIBRATION
10/19/2017

PUT ORP PROBE IN
470mV SOLUTION.

EXIT NEXT

2. Follow the instructions then press **NEXT** to continue.

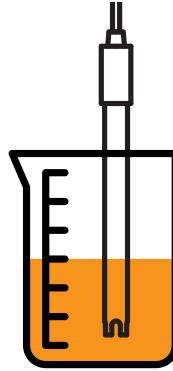

CONDUCTIVITY

1440 uS

WAIT FOR READING
TO STABILIZE THEN
PRESS DONE.

EXIT DNE

3. When the reading is stable, press **DONE** to complete the calibration.

Clear Calibration

MNU ► CALIBRATION ► NEXT

Calibration can be restored to factory defaults by selecting **CLEAR ALL**.

CALIBRATION

BACK

TEMPERATURE

PH

COND

CLEAR ALL

UP DWN ENT

1. Select **CLEAR ALL** from the calibration menu.

RESTORE TO
FACTORY
CALIBRATION?

YES NO

2. Press **YES** to restore factory calibration.

Advanced Calibration

Sensors values may be manually calibrated to alternate standards using the advance calibration features.

OFFSET calibration applies a linear offset adjustment to the value.
SPAN calibration applies an adjustment to the slope of the sensor value.

Note: pH is a temperature compensated (ATC) sensor. For accurate calibration, the temperature probe must be in the pH calibration standard. Allow all readings to stabilize before performing an offset or span calibration operation.

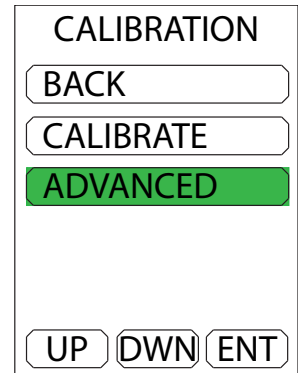

A screenshot of a terminal-style menu titled "CALIBRATION". It contains three buttons: "BACK", "CALIBRATE", and "ADVANCED". The "ADVANCED" button is highlighted in green. At the bottom, there are three buttons: "UP", "DWN", and "ENT".

Analog Output Calibration

4-20mA analog outputs may also be calibrated with a positive or negative offset to compensate for variation in DAC's/ADC's. The sensors' current output may be incrementally increased or decreased in steps of 0.005mA over a range of +/-2mA.

1 Offset bit = 0.005mA, Range = +/-400 bits (+/-2mA)

This calibration procedure is optional and only for use with custom PLC applications.

1. Observe the PLC's input or data readings.
2. Increase or decrease the offset value to incremenetally adjust the current output until the values match.

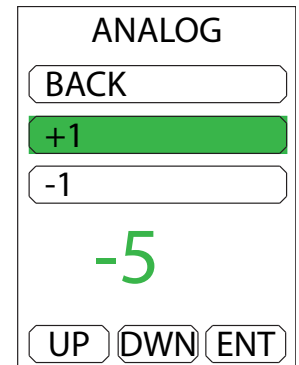

A screenshot of a terminal-style menu titled "ANALOG". It contains two buttons: "BACK" and "-1". The "-1" button is highlighted in green. Below the buttons, the number "-5" is displayed in green. At the bottom, there are three buttons: "UP", "DWN", and "ENT".

Setup Menu

MNU ► SETUP

The setup menu is where the time and date are set, the units are configured, logging interval is adjusted and advanced communications settings are available.

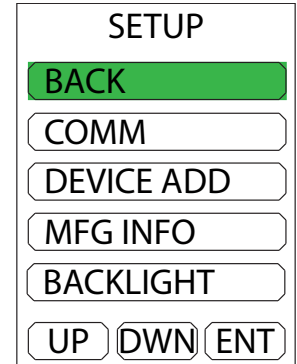
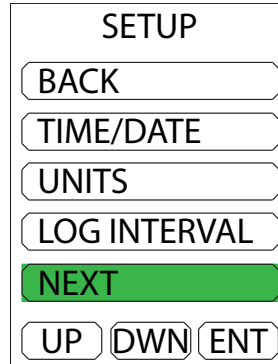

Time / Date

MNU ► SETUP ► TIME/DATE

Sensors include a precision real-time clock with battery back-up for time-stamping the data log information with the time and date. The last calibration for each sensor is also time stamped.

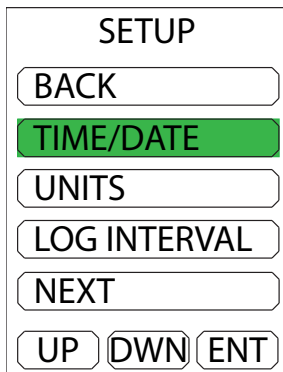

1. Select **TIME/DATE** from the setup menu.

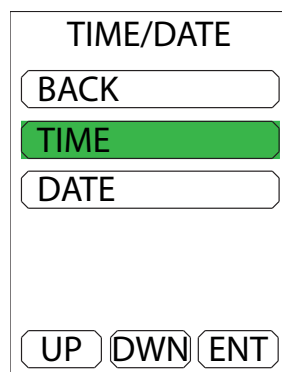

2. Select **TIME** or **DATE** to adjust.

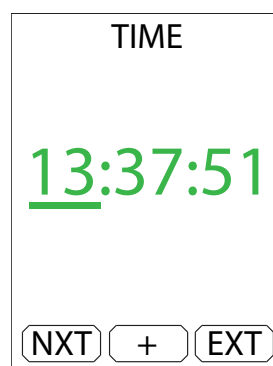

3. Use **NXT** to select the value to adjust. Use **+** to increment the value.

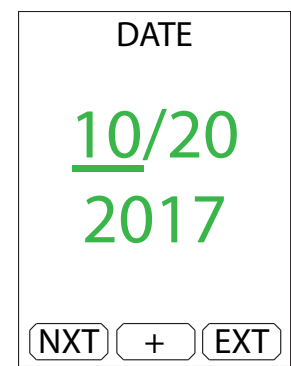

4. Use **EXT** to exit the menu.

Units

MNU ► SETUP ► UNITS

Temperature and Conductivity may be displayed in alternate units.

Select a sensor value to change the default display and working units.

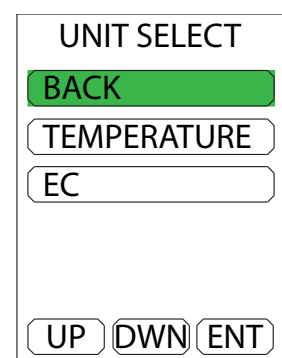
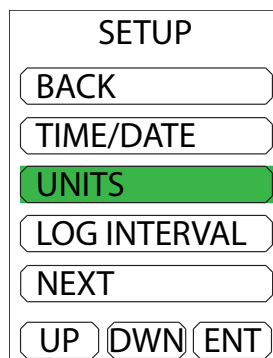

Configure temperature units:

Temperature may be displayed in °F or °C.

Note: Check alarm settings when converting temperature units.

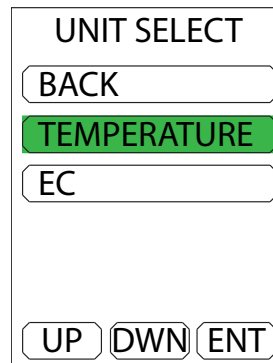

1. Select **TEMPERATURE** from the units menu.

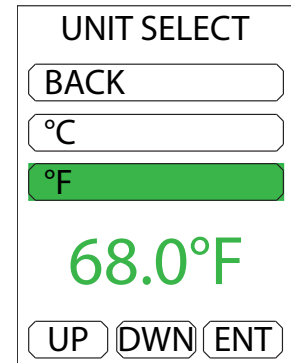

2. Select the desired units and press **ENT**.

Logging Interval

MNU ► **SETUP** ► **LOG INTERVAL**

Adjust the interval for recording data points in the on-board memory. Acceptable values are from 1 - 65535 seconds.

21,600 data points can be stored for each sensor value. The most recent 120 data points are shown on the graphical history.

The entire data history may be downloaded from the sensor to a .csv file with the LX1 USB AgrowLINK and free software.

Note: 60 second intervals = 15 days of data storage.

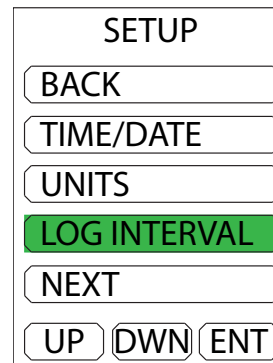

1. Select **LOG INTERVAL** from the setup menu.

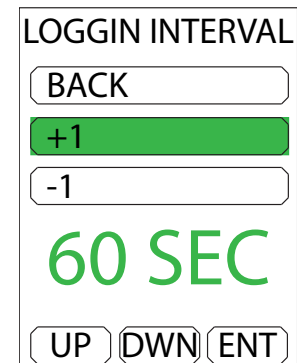

2. Adjust the value then select **BACK**.

COMM Mode

MNU ► SETUP ► NEXT ► COMM

COMM mode specifies whether the sensor is a normal passive device or “mini-master” device.

NORMAL Use with GrowControl master controller systems or stand-alone and data logging applications.

MINI-MASTER Use with MDX mini-dosing system. (GrowNET cross-over adapter required.)

SETUP

BACK

COMM

DEVICE ADD

MFG INFO

UP DWN ENT

1. Select **COMM** from the setup menu.

COM MODE

NORMAL

MINI MASTER

UP DWN ENT

2. Select a mode and press **ENT**.

Device Address

MNU ► SETUP ► NEXT ► DEVICE ADD

Sensors are digitally addressable from 1-249 and will be assigned an address automatically by Agrowtek’s control systems, or can be configured manually for MODBUS applications via the menu.

NOTE: All of Agrowtek’s devices use address 254 as a broadcast address.

SETUP

BACK

COMM

DEVICE ADD

MFG INFO

BACKLIGHT

UP DWN ENT

1. Select **DEVICE ADD** from the setup menu.

DEVICE ADDRESS

BACK

+1

-1

0 Addr

UP DWN ENT

2. Adjust the value then select **BACK**.

Manufacturing Info

MNU ► SETUP ► NEXT ► MFG INFO

Manufacturer information such as serial number, date of manufacture, hardware and firmware versions can be read from the MFG INFO page.

SETUP

BACK

COMM

DEVICE ADD

MFG INFO

BACKLIGHT

UP DWN ENT

1. Select **MFG INFO** from the setup menu.

SERIAL NUMBER:
17090554
DATE OF MFG:
09/15/17
HW VERSION:
C
FW VERSION:
02.03.84

EXIT

2. Press **EXIT** to return.

Display Back Light Timer

[MNU] ► [SETUP] ► [NEXT] ► [BACKLIGHT]

The display back light can be programmed to turn off after a specified time of inactivity from the last time a button is pressed.

The delay can be set from 1-255 minutes, or set to 0 to disable the back light timer and keep the display on continuously.

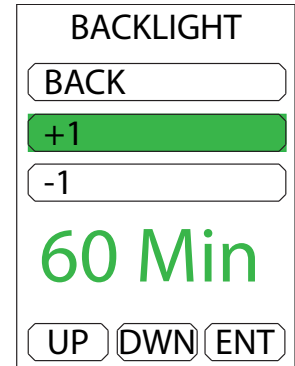
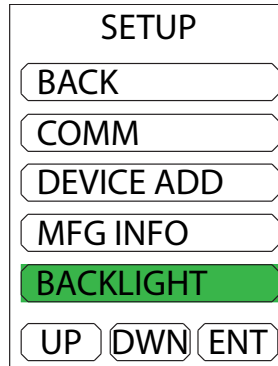

Connection to 4-20mA Outputs

Sensors are available with optional 4-20mA analog outputs. Use the LX3 DinLINK for wire connections. A mini-din 6 connector is included on units with 4-20mA outputs for power and analog connections. LX3 connects the mini-din 6 cable to a terminal block break-out with terminals for 24V power the four analog channels. 4-20mA linear outputs correspond to the ranges in the sensor specifications table.

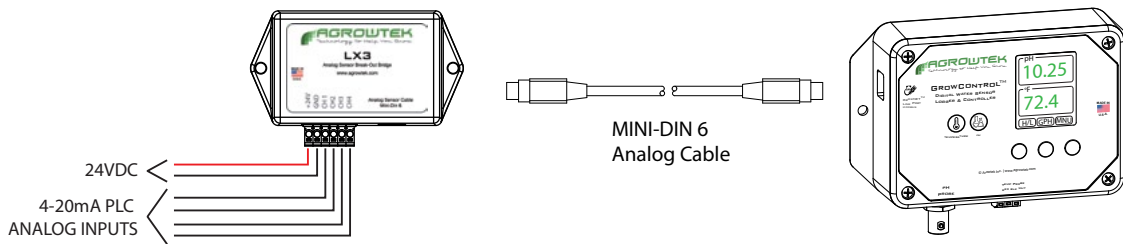

Connection to USB AgrowLINK

LX1 USB AgrowLINK connects Agrowtek's devices to a computer's USB port for:

- Firmware Updates
- Calibration
- Configuration
- Data Logging Download
- Live Graphing
- Email Alerts
- More

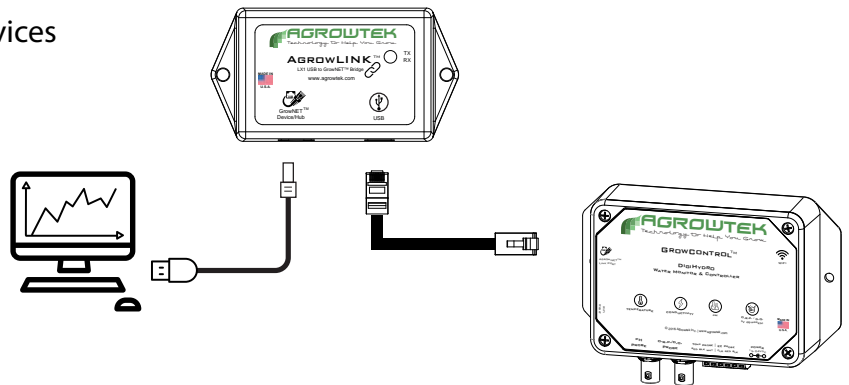

LX1 provides power from USB to operate SXH/SXH+

Sensor devices may be powered either by the power jack on the sensor, or by the power jack on the AgrowLINK. These options allow a single connection to the sensor through the Ethernet cable simplifying installation. Standard FTDI drivers automatically install in Windows. GrowNET protocol available for custom software applications; sample C# code available. See software manual for more information.

Connection to MODBUS RTU

RS-485 / RS-422

Use the LX2 ModLINK to connect MODBUS devices to the GrowNET™ port.

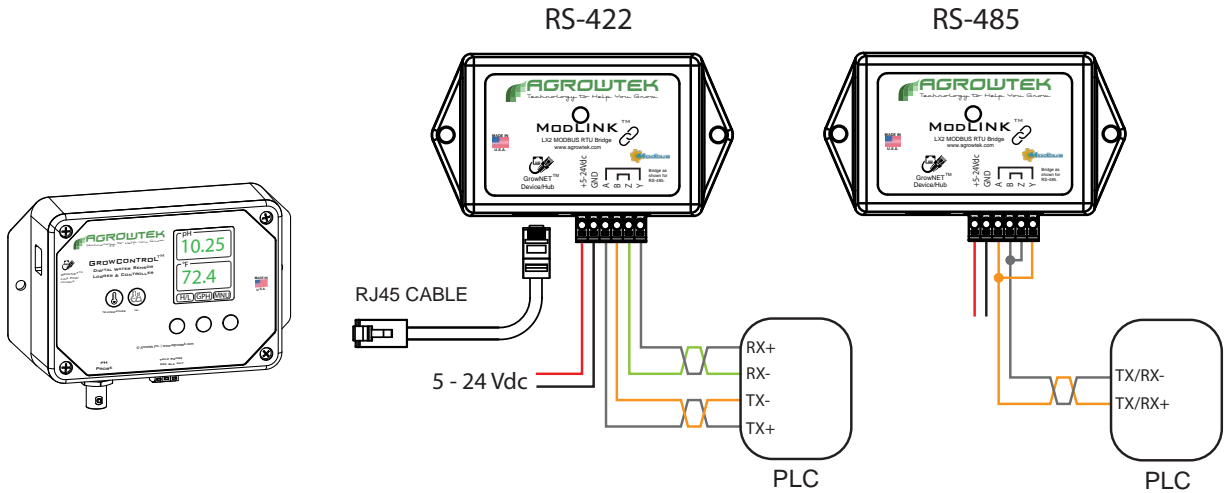

HX8 8-Port Hubs

HX8 GrowNET™ Hubs allow multiple GrowNET™ sensors, relays and dosing pumps to be connected to a single LX1 or LX2 interface. Individually buffered, full-duplex ports for signal integrity. Hubs can be daisy chained to form a network of up to 247 devices.

Hubs provide up to 1A of power for operating sensors and some relays directly over the GrowNET cable. A DC jack on the hub provides 24Vdc power to the ports from the included 120V wall power supply.

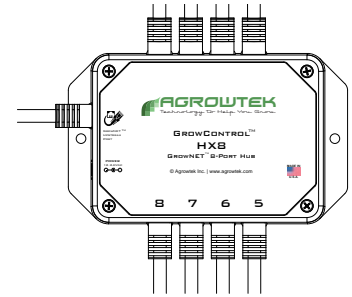

MODBUS Serial Speed & Format

The default serial data format for the LX2 ModLINK interface is: **19,200 baud, 8-N-1.**

Alternate speeds and formats between 9,600 - 115,200 baud may be configured with the free AgrowLINK PC utility using a LX1 USB AgrowLINK and the cross-over adapter supplied with the LX2 ModLINK.

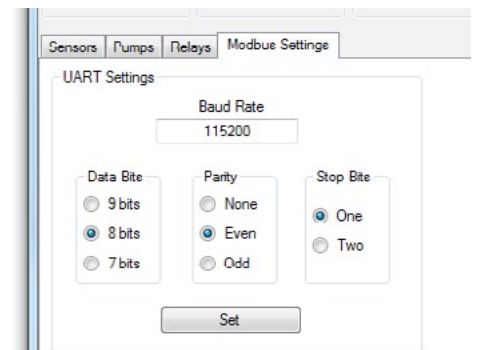
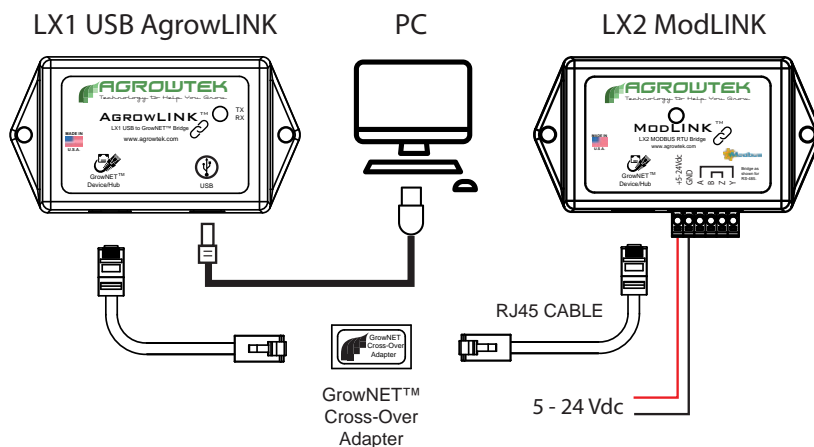

See MODBUS manual for more information.



Supported Commands

0x03 Read Multiple Registers
0x06 Write Single Register
0x10 Write Multiple Register

Register Types

All registers are 16 bits wide with addresses using the standard MODICON protocol. Floating point values use the standard IEEE 32-bit format occupying two contiguous 16 bit registers. ASCII values are stored with two characters (bytes) per register in hexadecimal format.

Sensor Value Registers

Sensor values are available in integer or floating point formats depending on the register (see map.)

Sensor #	Type	Integer Scale	Range
1	Temperature	x100	-2000 - 6000 (-20 - 60°C)
2	pH	x100	0 - 1400 (0 - 14.00pH)
3	O.R.P.	x1	-1000 - +1000 mV
	D.O.	x100	0 - 2000 (0 - 20.00 mg/L)

For example: an integer temperature value of 2417 is equal to a temperature reading of 24.17°C.

Calibration Registers

Calibration registers are 16-bit signed integers for the purpose of calibrating the sensor values or analog output channels. Calibration may be achieved by writing the desired calibrated value to the associated register. Writing to the calibration registers automatically invokes the calibration routine for that register.

Offset Calibration

Offset, or zero calibration, is an arithmetic positive or negative correction to the sensor reading. Operations performed using the offset register are:

- Temperature calibration
- pH 7 calibration

To perform a sensor offset calibration, simply write the corrected sensor value to the offset calibration register (taking into account the integer scale as shown above.)

To set the temperature to a calibrated value of 25°C, write the value "2500."

To set the pH 7 calibration, write the value "700."

Span Calibration

Span, or slope calibration, corrects the slope of the sensor reading at a second point, away from the zero calibration. Operations performed using the span register are:

-pH 4.01 or 10.0 calibration

To set the pH 4.01 calibration, write the value "401."

Note: perform any "offset" calibrations prior span calibrations.

Analog Calibration

Analog output calibration sends a positive or negative offset to the respective output channel's digital to analog converter (DAC.) The DAC has a resolution of 0.005mA/bit.

± 1 calibration bit = ± 0.005 mA adjustment

For example: to shift the analog output up by 0.1 mA, set the analog offset value to +20. ($0.1 / 0.005 = 20$)

MODBUS Register Map

Parameter	Function	Type	Scale	Access	Address
Device Address	Slave Address	Value, 1-247	8 bit	R/W	40001
Baud Rate	Comm baud rate	Value	16 bit	R	40002
Data Format	Comm data format	Value	16 bit	R	40003
Serial#	Serial Number	ASCII	8 Char	R	40004
DOM	Date of Manufacture	ASCII	8 Char	R	40008
HW Version	Hardware Version	ASCII	8 Char	R	40012
FW Version	Firmware Version	ASCII	8 Char	R	40016
Sensor 1 Value	Sensor output	Signed Int	16 bit	R	40101
Sensor 2 Value	Sensor output	Signed Int	16 bit	R	40102
Sensor 3 Value	Sensor output	Signed Int	16 bit	R	40103
Sensor 1 Value	Sensor output	Float	32-bit	R	40201
Sensor 2 Value	Sensor output	Float	32-bit	R	40203
Sensor 3 Value	Sensor output	Float	32-bit	R	40205
Sensor 1 Offset Cal	Calibration Input	Signed Int	16 bit	W	41101
Sensor 2 Offset Cal	Calibration Input	Signed Int	16 bit	W	41102
Sensor 3 Offset Cal	Calibration Input	Signed Int	16 bit	W	41103
Sensor 1 Span Cal	Calibration Input	Signed Int	16 bit	W	41201
Sensor 2 Span Cal	Calibration Input	Signed Int	16 bit	W	41202
Sensor 3 Span Cal	Calibration Input	Signed Int	16 bit	W	41203
Sensor 1 Analog Cal	Calibration Input	Signed Int	16 bit	W	41301
Sensor 2 Analog Cal	Calibration Input	Signed Int	16 bit	W	41302
Sensor 3 Analog Cal	Calibration Input	Signed Int	16 bit	W	41303

Maintenance

Sensor probes require periodic cleaning, reconditioning and calibration for reliable service. See calibration section for details on performing calibration service after cleaning.

Probe Cleaning

Coating of the pH or ORP bulbs can lead to erroneous readings including shortened span (slope). Coatings and blockages in the EC sensor can cause incorrect readings. The type of coating will determine the cleaning technique.

Soft coatings can be removed by vigorous stirring or by the use of a squirt bottle.

Organic chemical or hard coatings should be chemically removed. 5-10% hydrochloric acid (HCl) soak for a few minutes and often removes many coatings.

If cleaning does not restore pH sensor performance, reconditioning may be tried.

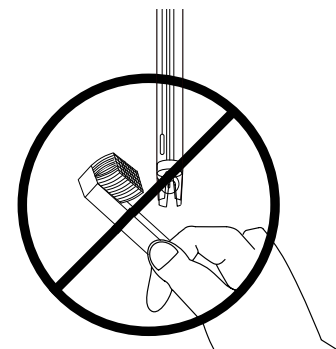

Do not use a brush or abrasive on pH or EC probes.

pH Probe Reconditioning

When reconditioning is required due to electrode aging the following chemical treatments can be tried. They are presented in the order of the severity of attack on the pH glass and may not improve (and in some cases actually further deteriorate) electrode performance.

⚠ DANGER: Use proper precautions when handling these hazardous chemicals. Ammonium bifluoride and HF (hydrofluoric acid) are extremely hazardous and should only be used by qualified personnel.

Reconditioning Method 1

Immerse the electrode tip in 0.1 N HCl for 15 seconds, rinse in tap water and then immerse tip in 0.1 M NaOH for 15 seconds and rinse in tap water. Repeat this sequence three times and then recheck the electrode's performance. If performance has not been restored, try method two.

Reconditioning Method 2

Immerse the tip in a 20% solution of NH₄F-HF (ammonium bifluoride) for two to three minutes, rinse in tap water and recheck performance. If performance has not been restored, try method three.

Reconditioning Method 3

Immerse electrode tip in 5% HF for 10-15 seconds, rinse well in tap water, quickly rinse in 5N HCl, rinse well in tap water and recheck performance. If performance has not been restored, it is time to get a new probe.

Technical Information

Specifications

Power	5-24Vdc, ~2W (5W w/LCD)
Max Cable Distance	1000ft
Optional Interface	LCD w/3 Buttons
Temperature Range	-20 - 60°C
Temperature Accuracy	±2°C, 0.01° resolution
pH Range	0-14pH
pH Accuracy	±0.02pH, 0.01pH resolution
+ORP (DO) Range	-1000 - +1000mV (0-20mg/L)
+ORP (DO) Accuracy	±10mV, 1mV resolution (±0.1mg/L, 0.1 resolution)
4-20mA Output Resolution	12 bit , 0.005mA
Interface	GrowNET, MODBUS or WiFi

Storage & Disposal

Storage

Store equipment in a clean, dry environment with ambient temperature between 10-50°C.

Disposal

This industrial control equipment may contain traces of lead or other metals and environmental contaminants and must not be discarded as unsorted municipal waste, but must be collected separately for the purpose of treatment, recovery and environmentally sound disposal. Wash hands after handling internal components or PCB's.

Warranty

Agrowtek Inc. warrants that all manufactured products are, to the best of its knowledge, free of defective material and workmanship and warrants this product for 1 year from the date of purchase. This warranty is extended to the original purchaser from the date of receipt. This warranty does not cover damages from abuse, accidental breakage, or units that have been modified, altered, or installed in a manner other than that which is specified in the installation instructions. Agrowtek Inc. must be contacted prior to return shipment for a return authorization. No returns will be accepted without a return authorization. This warranty is applicable only to products that have been properly stored, installed, and maintained per the installation and operation manual and used for their intended purpose. This limited warranty does not cover products installed in or operated under unusual conditions or environments including, but not limited to, high humidity or high temperature conditions. The products which have been claimed and comply with the aforementioned restrictions shall be replaced or repaired at the sole discretion of the Agrowtek Inc. at no charge. This warranty is provided in lieu of all other warranty provisions, express or implied. It is including but not limited to any implied warranty of fitness or merchantability for a particular purpose and is limited to the Warranty Period. In no event or circumstance shall Agrowtek Inc. be liable to any third party or the claimant for damages in excess of the price paid for the product, or for any loss of use, inconvenience, commercial loss, loss of time, lost profits or savings or any other incidental, consequential or special damages arising out of the use of, or inability to use, the product. This disclaimer is made to the fullest extent allowed by law or regulation and is specifically made to specify that the liability of Agrowtek Inc. under this limited warranty, or any claimed extension thereof, shall be to replace or repair the Product or refund the price paid for the Product.